

PD Series Platform scale

The PD series Complete Weighing scale are easy-to operate its economical indicator housed in A.B.S enclosure with mild steel Structure and Stainless steel Top Cover.

Features:

- Hi resolution Weighing Indicator.
- High Quality / economical Cost
- Up to 1/10,000 display resolution
- Weight backup
- Low power and overload indication
- A.B.S Enclosure, equipped with desktop bracket
- weight unit Kg and selectable decimal point position
- Full duplex RS232 with multiple communication protocols

Specifications:

Input sensitivity:	0.1 μ V/d(Min)
Input single range:	0~12.8mv
Load cell excitation:	3.3VDC
Stabilization time:	1 second typical
Operating temperature:	0° c ~ 50° c / 32° F ~ 122° F
Non-linearity:	0.01% of F.S
A/D resolution:	3000e
keys:	"on/off", "Total", "Hold", "Tare", "Zero", "Set"
Maximum Display:	999999
Minimum Division:	1 X 2 X 5 X 10 X 20 X 50.
Under zero Indication:	"-" minus display
Display Indications :	Hi, Ok, Lo, Battery Charging, Hold, Auto, Net, Gross, Tare & Total
Battery:	4V DC/4Ah
Power:	220V AC 50 Hz



Display:

Large LCD and LED Display is easy to read

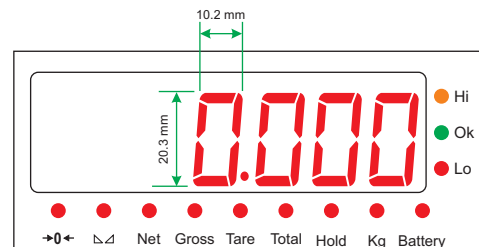
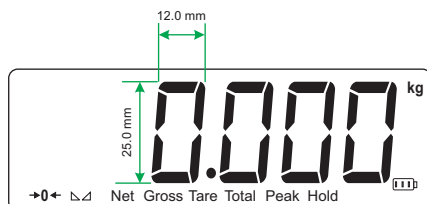

It is equipped with a large easy to read 6 digits 0.8" LED or LCD display.

A full duplex RS-232 port can transmit data on demand or continuously to match the input requirement of a wide variety of devices including printers. Remote displays and computers.

Rechargeable battery or AC 220V operated.

Available Indicators:



D60 Indicator:

General Weighing, ABS Housing.
Low Battery Remainder.
Rechargeable battery or AC 220V operated.



D800 Indicator:

General Weighing, M.S Housing paint finish.
Low Battery Remainder.
6V DC Rechargeable battery or AC 220V operated.



D900s Indicator:

Stainless housing Ip67 with Outstanding performance.
Full Duplex RS-232 Serial Port, Data hold function.
6V DC Rechargeable battery or AC 220V operated.

Platforms:

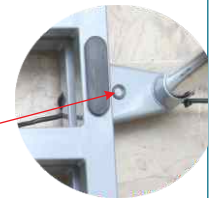
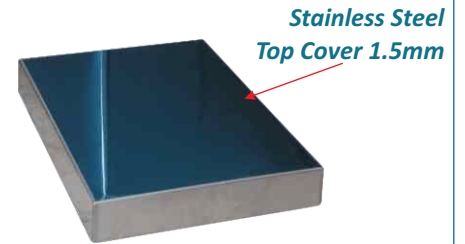
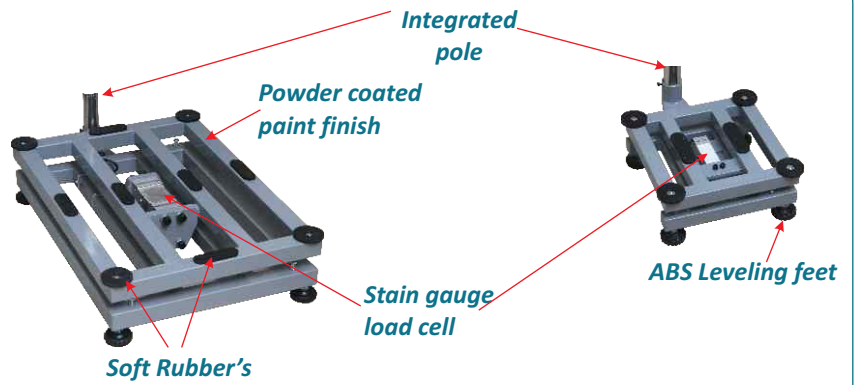

Keypad:

Large keys and smart layout for easy operations

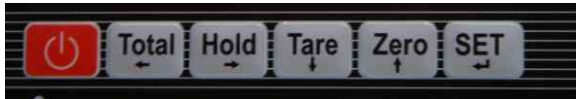

Physical Dimensions:

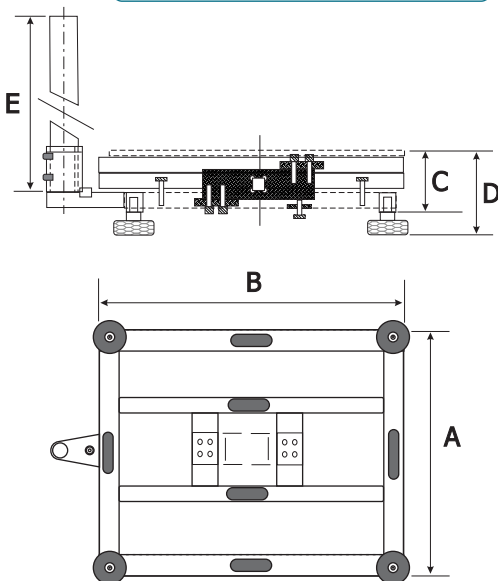

Platform Sizes

Model	Capacity/Division	A	B	C	D	E
PD-300	30 kg X 0.001 kg	300	300	90	125	410
PD-400	50 kg X 0.002 kg	400	400	100	125	625
PD-450	100 kg X 0.005 kg	400	500	103	130	625
PD-500	200 kg X 0.01 kg	500	500	125	160	860
PD-570	300 kg X 0.02 kg	500	700	125	160	860
PD-600	300 kg X 0.02 kg	600	600	125	160	860
PD-700	500 kg X 0.05 kg	700	700	125	160	860



Weighing Solution
www.sang-weighing.com
info@sang-weighing.com

Reliable and Rugged!